

iHSV57-SC

Integrated AC Servo Motors with Brake

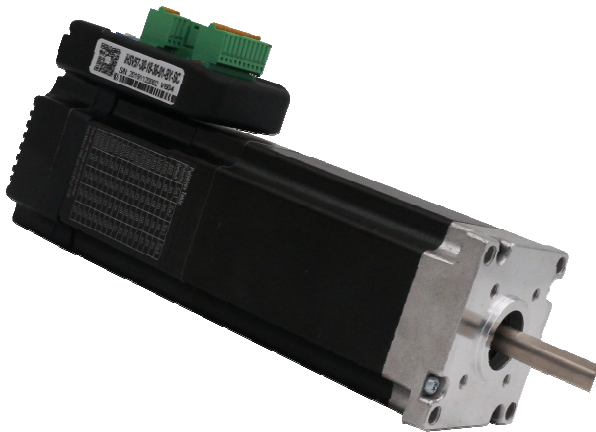

1. Features:

- High positioning accuracy
- High torque
- Cost-effective high speed response
- Smooth and very low noise
- Compact size
- Pulse Input Mode Pulse + Direction
- Current Loop Bandwidth: (-3dB) 2KHz (Typical)
- Speed Loop Bandwidth: 500Hz (Typical)
- Position Loop Bandwidth: 200Hz (Typical)
- Parameters to download via RS232 to PC.
- Users can define subdivisions via external Dial-up switches or via software.
- Over-current, I²T-motor-current-observation, Over-voltage, Under-voltage, Over-heat, Over-speed, protections.

2. Description:

The iHSV57-XX-SC AC servo motor consists of a perfectly tuned servo driver integrated into a servo motor. The vector-controlled system with DSP chip allows three adjustable modes (position loop, speed loop, and current loop) in one unit and is completed with a brake. The system saves space by eliminating the wiring between driver, motor, and encoder. iHSV57-XX-SC is a product from a model range for applications in motion control.

3. Applications:

iHSV57-XX-SC can be used in various applications such as laser cutters, laser markers, high precision X-Y tables, labelling machines, CNC router, etc. Its unique features make the iHSV57-XX-SC an ideal choice for applications that require low-speed smoothness and high torque at higher revolution by small mounting space.

4. Naming Rules:

iHSV 5 7 - 3 0 - 1 0 - 3 6 - XX - XX

1 2 3 4 5 6 7

1. Integrated Servo motor
2. Motor frame size: 57
3. Motor revolution (unit: x 100 RPM) 10 \triangleq 1000 RPM, 20 \triangleq 2000 RPM, 30 \triangleq 3000 RPM
4. Output Power (unit: x 10 W) 10 \triangleq 100 W; 20 \triangleq 200 W
5. Motor rated DC voltage: 24 means voltage is 24 V, 36 means voltage is 36 V.
6. Shaft length: 01 = 30 mm, 21 = 21 mm
7. Pilot diameter: No digit = 25.4 mm, 38 = 38.1 mm
8. SC = with Brake; RC = with MOD-/CAN Bus

5. Electrical Specifications:

Parameters:	Min	Typical	Max	Unit:
Input Voltage :	20	36	50	Vdc
Output current :		6		A
Pulse per revolution:	4	-	51200	Pul./rev.
Pulse input frequency:		-	200	kHz
Pulse Voltage:	3.3	5	24 (with R= 5k Ω)	V
Logic Signal Current:	7	10	16	mA
Isolation Resistance:	100	-	-	M Ω
Brake:				
Input Voltage:		24		VDC
Current:		0,125		A

iHSV57-SC

Integrated AC Servo Motors with Brake

6. Motor Specifications:

Name:	iHSV57-30-18-36-XX-SC		Unit
Rated Power	180		W
Rated Torque	0.57		N·m
Rated Speed	3000		min ⁻¹
Max. Speed	3000		min ⁻¹
Rated Voltage	36		V
Weight	1.6		kg
Max. Cogging torque	14.9		mN·m

7. Operating Environment:

Cooling	Natural cooling or forced cooling	
Operating Environment	Environment	Avoid dust, oil, fog and corrosive gases
	Ambient Temperature	0°C – 40°C
	Humidity	40 %RH – 90 %RH
	Operating Temperature	max. 70°C
Storage Temperature	-20°C – 80°C	

8. Mechanical Specification:

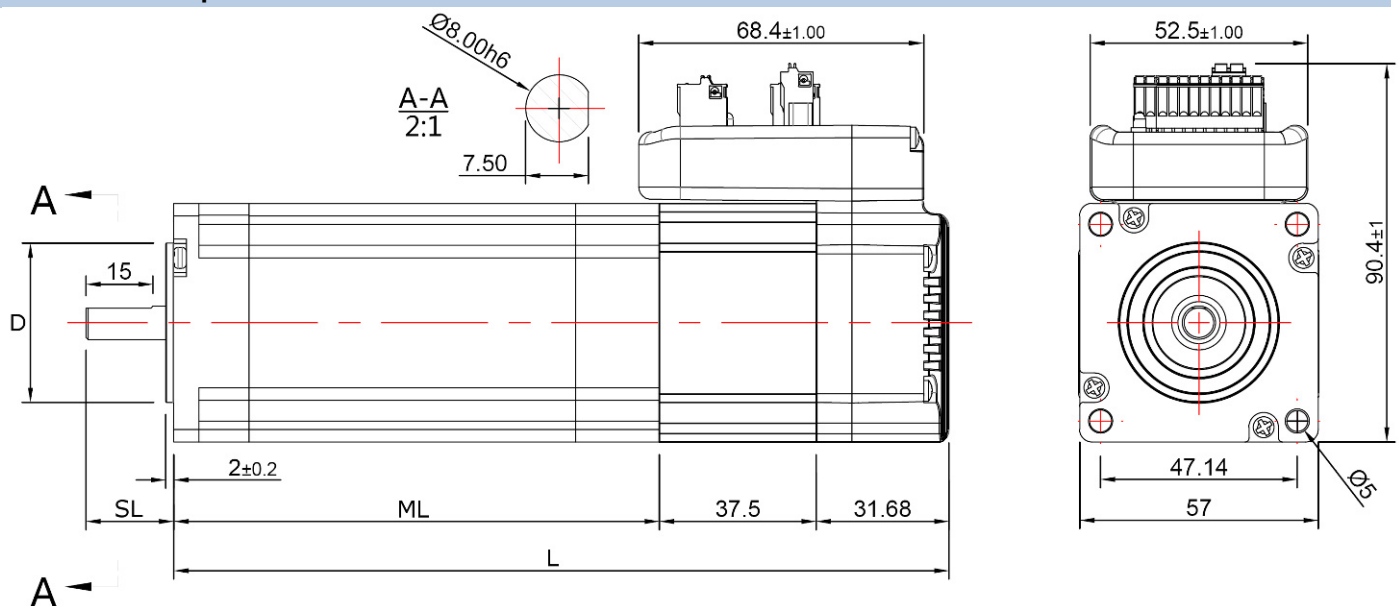

Name:	Motor length ML	Length motor + drive L	Shaft Length SL	Pilot Diameter D
iHSV57-30-18-36-21-38	116 mm	150 mm	21 ± 1 mm	38,1 mm
iHSV57-30-18-36-01	116 mm	150 mm	30 ± 1 mm	25,4 mm

9. Protection Indications:

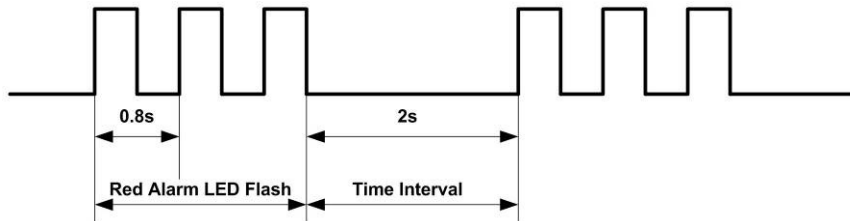

LED light flashes	Alarm description
2 times	Drive over current
3 times	Driver position deviation exceeds set value
4 times	Driver encoder alarm
6 times	Under voltage
7 times	Driver overload

10. Connectors and Pin Assignment

The iHSV57-XX has three connectors, one connector for power connections for the Driver, another one for control signal connections (Power Connection for the Brake is located here) and a third one for RS232 communication connections.

Power Connector +VDC			
Pin	Name	I/O	Description
1	DC+	I	Power Supply Input (Positive) 43 – 53 / 65 - 79VDC; 48 / 72 V is typical. Recommended to leave reasonable reserve for voltage fluctuation and back-EMF during deceleration.
2	GND	GND	Power Ground (Negative)

Control Signal Connector			
Pin	Name	I/O	Description
1	ALM-	O	Alarm Signal: OC output signal, activated when one of the following protection is activated: over-voltage and over current error. They can sink or source MAX 8 mA current at 24 V, respectively 200 mW. The impedance between ALM+ and ALM- is high for normal operation and becomes low when any protection is activated.
2	ALM+	O	
3	BRK-	I	Power supply for the brake. This connector must be connected to a 24V power supply to operate the motor. The brake is only released if the following conditions are met: 24V is connected; no alarm is active; ENA is enabled (see ENA description); no power failure of the motor. The brake fixes the motor when one of the following events occurs: Alarm has been triggered; ENA is not enabled; motor power failure. The PED signal is not available for this motor.
4	BRK+	I	
5	ENA-	I	Enable signal: This signal is used for enabling/disabling the drive board. By default, high level (NPN control signal) for enabling the drive board and low level for disabling the drive board. It is usually left UNCONNECTED (ENABLED) . Please note that the PNP and Differential control signals are on the contrary, namely Low level for enabling. (optional: SW5 ON direction of rotation CW/CCW)
6	ENA+	I	
7	DIR-	I	Direction Signal: In single-pulse mode, this signal has low/high voltage levels, representing two directions of motor rotation. For reliable motion response, DIR signal should be ahead of PUL signal by 5µs at least. 3.5-24V for DIR-HIGH, 0-0.5V for DIR-LOW. Toggle DIP switch S6 to reverse motion direction. (optional: SW5 ON direction of rotation CW/CCW)
8	DIR+	I	
9	PUL-	I	Pulse Signal: In single pulse (pulse/direction) mode, this input represents pulse signal, active at each rising or falling edge (Software configurable). 3.5 – 24 V for PUL-HIGH, 0 - 0.5 V for PUL-LOW. For reliable response, pulse width should be longer than 2.5µs for 200kHz MAX input frequency.
10	PUL+	I	

RS232 Communication Port				
Pin	Name	Colour at round beige Cable	Colour at flat grey Cable	Description
1	NC	-	-	Not used
2	RX	Brown-White	Yellow	RS232 Receive Data
3	GND	Blue	Green	Ground
4	TX	Blue-White	Red	RS232 Transmit Data
5	VCC	-	-	Power Supply 3.3 V to HISU. Attention: For PC software use, leave unconnected!

Note 1: The RS232 communication port is not isolated. Please use an isolated power supply for the iHSSXX when the PC's serial port is not isolated.

Note 2: Do not plug or unplug the connector when power is on.

11. DIP Switch Settings:

Pulses per revolution of the iHSS-XX can be configured via DIP switch SW1-SW4 or by the tuning software. When all SW1-SW4 are at "ON" positions, the drive will take the setting set by the software. In this case, a user can re-configure to any value between 4 and 51200 through software. If any bit of SW1-SW4 is at "OFF" position, the integrated drive board will take micro step resolution setting determined by bit positions of SW1-SW4. Use the following table for their resolution settings via the DIP switches.

Pulses / Revolution	SW1	SW2	SW3	SW4
Software configured	On	On	On	On
800	Off	On	On	On
1600	On	Off	On	On
3200	Off	Off	On	On
6400	On	On	Off	On
12800	Off	On	Off	On
25600	On	Off	Off	On
51200	Off	Off	Off	On
1000	On	On	On	Off
2000	Off	On	On	Off
4000	On	Off	On	Off
5000	Off	Off	On	Off
8000	On	On	Off	Off
10000	Off	On	Off	Off
20000	On	Off	Off	Off
40000	Off	Off	Off	Off

SW 5: With SW5 the pulse mode can be configured. OFF (off) stands for PUL/DIR mode. ON (on) for CW/CCW

SW 6: is used for setting the running direction, "off" means CCW, while "on" means CW.

SW 7: is used for PUL Filter Setting, "off" means Max. PUL frequency is 200 kHz, on means Max. PUL frequency is 100 kHz. Note: When the P22 parameter is 0, the pulse filtering degree is controlled by the SW7 pulse interference filtering dialling code, when set to other non-zero values, SW7 does not work.

SW 8: is used for PUL Smoothing Setting, "off" means switch off PUL Smoothing, "on" means switch on PUL Smoothing.

12. Fine Tuning:

Standard parameters are already set ex works. These standard parameter values are optimized and suitable for most industrial applications. In most cases it is not necessary to change them. However, if you want to optimize the performance for your application, the software can be used to adjust these parameters

13. Typical Connections:

Connection to Common Anode:

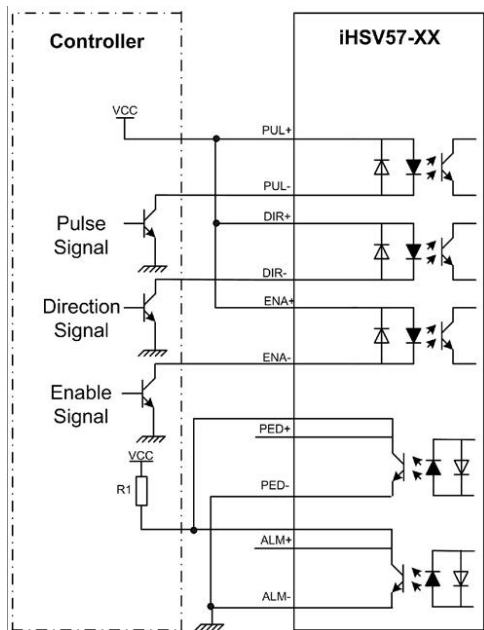

Connection to Common Cathode:

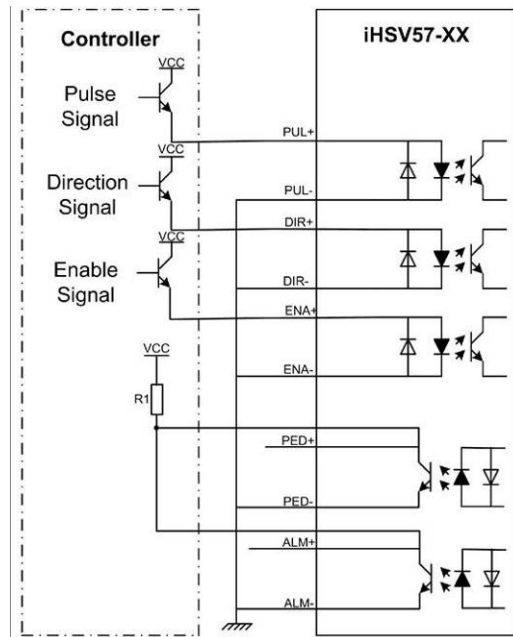

Connection to Differential Signal:

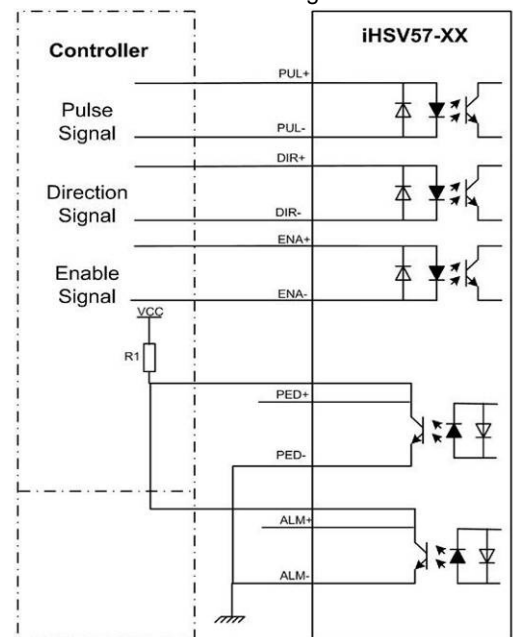

14. RS232 Communication Cable Connections:

Note 1: The RS232 communication port is not isolated. Please use a galvanic isolated power supply for the iHSS86-XX when the PC's serial port is not isolated.

Note 2: Do not plug or unplug the connector when power is on.

Definition		Remark
RX	○ ▷	Receive Data
GND	○ ▷	Power Ground
TX	○ ▷	Transmit Data
OR		
NC	○ ▷	Reserved
RX	○ ▷	Receive Data
GND	○ ▷	Power Ground
TX	○ ▷	Transmit Data
VCC	○ ▷	Power Supply to HISU

15. Connection of the Brake

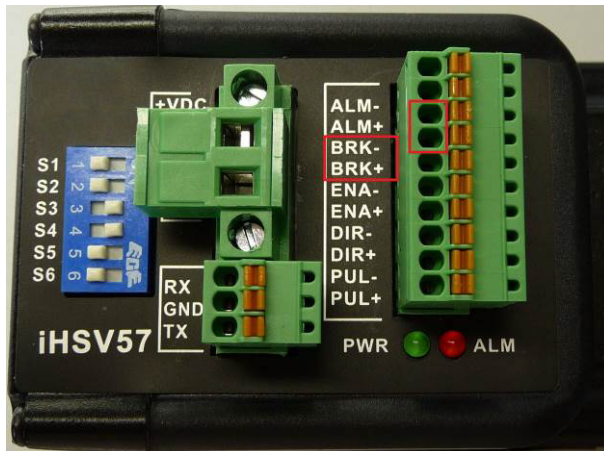

To operate the motor, the brake must be supplied with 24V. If the brake is not supplied with the correct voltage (24V) and sufficient current (150mA), it is fixed. It is strongly recommended not to operate the motor with the brake fixed, as the increased current consumption can damage the electronics.

Attention! No protection against polarity reversal!

Brake is fixed at:

- Alarm Signal active
- Enable Signal inactive
- Error in the power connection of the motor
- Error in the power connection of the brake

The PED signal is not available for this motor type.