

# iHSV86

# Integrated AC Servo Motors



## 1. Features:

- High positioning accuracy
- High torque
- Cost-effective high speed response
- Smooth and very low noise
- Compact size
- Pulse Input Mode Pulse + Direction
- Current Loop Bandwidth: (-3dB) 2KHz (Typical)
- Speed Loop Bandwidth: 500Hz (Typical)
- Position Loop Bandwidth: 200Hz (Typical)
- Parameters to download via RS232 to PC.
- Users can define subdivisions via external Dial-up switches or via software.
- Over-current, I2T-motor-current-observation, Over-voltage, Under-voltage, Over-heat, Over-speed, protections.

## 2. Description:

The iHSV86-XX AC servo motor consists of a perfectly tuned servo driver integrated in a servo motor, vector controlled and with DSP chip. The system saves installation space, cabling between driver, motor and encoder, and is very profitable due to its low purchase price.

## 3. Applications:

iHSV86-XX can be used in various applications such as laser cutters, laser markers, high precision X-Y tables, labelling machines, CNC router, etc. Its unique features make the iHSV86-XX an ideal choice for applications that require low-speed smoothness and high torque at higher revolution by small mounting space.

## 4. Naming Rules:

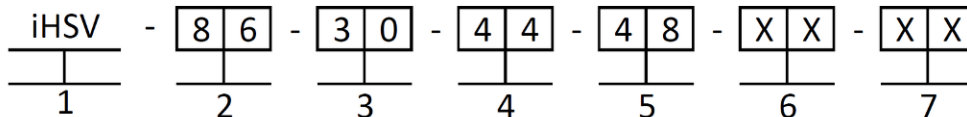

1. Integrated Servo motor
2. Motor frame size: 86 mm
3. Motor revolution (unit: x 100 min<sup>-1</sup>) 10  $\triangleq$  1000 min<sup>-1</sup>, 20  $\triangleq$  2000 min<sup>-1</sup>, 30  $\triangleq$  3000 min<sup>-1</sup>
4. Output Power (unit: x 10 W) 10  $\triangleq$  100 W; 20  $\triangleq$  200 W; 44  $\triangleq$  440W
5. Motor rated DC voltage: 24  $\triangleq$  24 V, 36  $\triangleq$  36 V, 48  $\triangleq$  48V
6. Shaft length: No digit  $\triangleq$  38mm
7. Pilot diameter: No digit at iHSV86 = 73 mm

## 5. Electrical Specifications:

Parameters:	Min		Typical		Max		Unit
	iHSV86-30-44-48	iHSV86-30-66-72	iHSV86-30-44-48	iHSV86-30-66-72	iHSV86-30-44-48	iHSV86-30-66-72	
Input Voltage :	43	65	48	72	53	79	VDC
Output current :			13,1	13,1	19,6	19,6	A
Pulse per revolution:	4		-		51200		-
Pulse input frequency:			-		200		kHz
Pulse Voltage	3.3		5		24 (with R 3 - 5 k $\Omega$ )		V
Logic Signal Current	7		10		16		mA
Isolation Resistance	100		-		-		M $\Omega$

# iHSV86

# Integrated AC Servo Motors

## 6. Motor Specifications:

Name:	iHSV86-30-44-48	iHSV86-30-66-72			Unit
Rated Power	440	660			W
Rated Torque	1,4	2,1			Nm
Rated Speed	3000	3000			min <sup>-1</sup>
Max. Speed	4000	4000			min <sup>-1</sup>
Rated Voltage	48	72			V
Weight	3,5	4,5			kg

## 7. Operating Environment:

Cooling	Natural cooling or forced cooling	
Operating Environment	Environment	Avoid dust, oil, fog and corrosive gases
	Ambient Temperature	0°C – 40°C
	Humidity	40 %RH – 90 %RH
	Operating Temperature	max. 70°C
Storage Temperature	-20°C – 80°C	

## 8. Mechanical Specification:

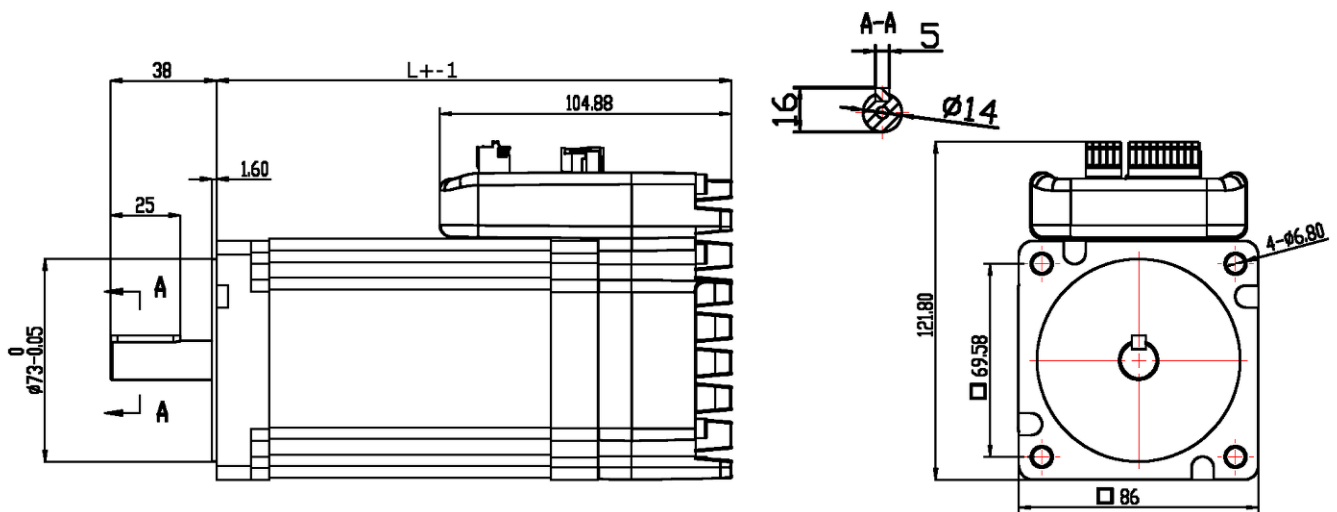

Name:	□ Bore Distance	Length of motor and drive (L)	Shaft Length	Pilot Diameter
iHSV86-30-44-48	69,58 mm	158 ±1 mm	38 ±1 mm	73 mm
iHSV86-30-66-72	69,58 mm	185±1 mm	38 ±1 mm	73 mm

## 9. Protection Indications:

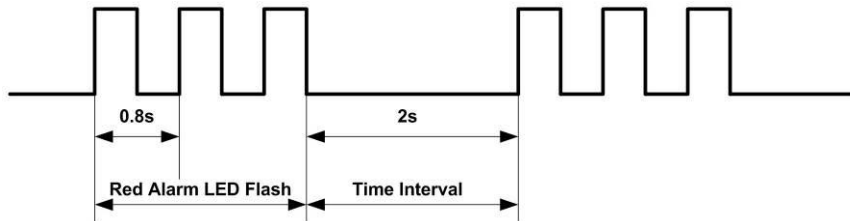

LED light flashes	Alarm description
2 times	Drive over current
3 times	Driver position deviation exceeds set value
4 times	Driver encoder alarm
6 times	Under Voltage
7 times	Driver overload

## 10. Connectors and Pin Assignment

The iHSV86-XX has three connectors, one connector for power connections, another one for control signal connections and a third one for RS232 communication connections.

Power Connector +VDC			
Pin	Name	I/O	Description
1	DC+	I	Power Supply Input (Positive) 43 – 53 / 65 - 79VDC; 48 / 72 V is typical. Recommended to leave reasonable reserve for voltage fluctuation and back-EMF during deceleration.
2	GND	GND	Power Ground (Negative)

Control Signal Connector			
Pin	Name	I/O	Description
1	ALM-	O	<b>Alarm Signal:</b> OC output signal, activated when one of the following protection is activated: over-voltage and over current error. They can sink or source MAX 8 mA current at 24 V, respectively 200 mW. The impedance between ALM+ and ALM- is high for normal operation and becomes low when any protection is activated.
2	ALM+	O	
3	PED-	O	<b>In-position Signal:</b> OC output signal, activated when actual motor position reaches to target Position. This port can sink or source MAX 8 mA current at 24 V, respectively 200 mW. The impedance between PED+ and PED- is high for normal operation and becomes low when the target position is reached.
4	PED+	O	
5	ENA-	I	<b>Enable signal:</b> This signal is used for enabling/disabling the drive board. By default, high level (NPN control signal) for enabling the drive board and low level for disabling the drive board. It is usually left <b>UNCONNECTED (ENABLED)</b> . Please note that the PNP and Differential control signals are on the contrary, namely Low level for enabling. (optional: SW5 ON direction of rotation CW/CCW)
6	ENA+	I	
7	DIR-	I	<b>Direction Signal:</b> In single-pulse mode, this signal has low/high voltage levels, representing two directions of motor rotation. For reliable motion response, DIR signal should be ahead of PUL signal by 5µs at least. 3.5-24V for DIR-HIGH, 0-0.5V for DIR-LOW. Toggle DIP switch S6 to reverse motion direction. (optional: SW5 ON direction of rotation CW/CCW)
8	DIR+	I	
9	PUL-	I	<b>Pulse Signal:</b> In single pulse (pulse/direction) mode, this input represents pulse signal, active at each rising or falling edge (Software configurable). 3.5 – 24 V for PUL-HIGH, 0 - 0.5 V for PUL-LOW. For reliable response, pulse width should be longer than 2.5µs for 200kHz MAX input frequency.
10	PUL+	I	

RS232 Communication Port				
Pin	Name	Colour at round beige Cable	Colour at flat grey Cable	Description
1	NC	-	-	Not used
2	RX	Brown-White	Yellow	RS232 Receive Data
3	GND	Blue	Green	Ground
4	TX	Blue-White	Red	RS232 Transmit Data
5	VCC	-	-	Power Supply 3.3 V to HISU. Attention: For PC software use, leave unconnected!

**Note 1:** The RS232 communication port is not isolated. Please use an isolated power supply for the iHSSXX when the PC's serial port is not isolated.

**Note 2:** Do not plug or unplug the connector when power is on.

### 11. DIP Switch Settings:

Pulses per revolution of the iHSS-XX can be configured via DIP switch SW1-SW4 or by the tuning software. When all SW1-SW4 are at "ON" positions, the drive will take the setting set by the software. In this case, a user can re-configure to any value between 4 and 51200 through software. If any bit of SW1-SW4 is at "OFF" position, the integrated drive board will take micro step resolution setting determined by bit positions of SW1-SW4. Use the following table for their resolution settings via the DIP switches.

Pulses / Revolution	SW1	SW2	SW3	SW4
Software configured	On	On	On	On
800	Off	On	On	On
1600	On	Off	On	On
3200	Off	Off	On	On
6400	On	On	Off	On
12800	Off	On	Off	On
25600	On	Off	Off	On
51200	Off	Off	Off	On
1000	On	On	On	Off
2000	Off	On	On	Off
4000	On	Off	On	Off
5000	Off	Off	On	Off
8000	On	On	Off	Off
10000	Off	On	Off	Off
20000	On	Off	Off	Off
40000	Off	Off	Off	Off

**SW 5:** With SW5 the pulse mode can be configured. OFF (off) stands for PUL/DIR mode. ON (on) for CW/CCW

**SW 6:** is used for setting the running direction, "off" means CCW, while "on" means CW.

**SW 7:** is used for PUL Filter Setting, "off" means Max. PUL frequency is 200 kHz, on means Max. PUL frequency is 100 kHz.

Note: When the P22 parameter is 0, the pulse filtering degree is controlled by the SW7 pulse interference filtering dialling code, when set to other non-zero values, SW7 does not work.

**SW 8:** is used for PUL Smoothing Setting, "off" means switch off PUL Smoothing, "on" means switch on PUL Smoothing.

## 12. Fine Tuning:

Standard parameters are already set ex works. These standard parameter values are optimized and suitable for most industrial applications. In most cases it is not necessary to change them. However, if you want to optimize the performance for your application, the software can be used to adjust these parameters

## 13. Typical Connections:

Connection to Common Anode:

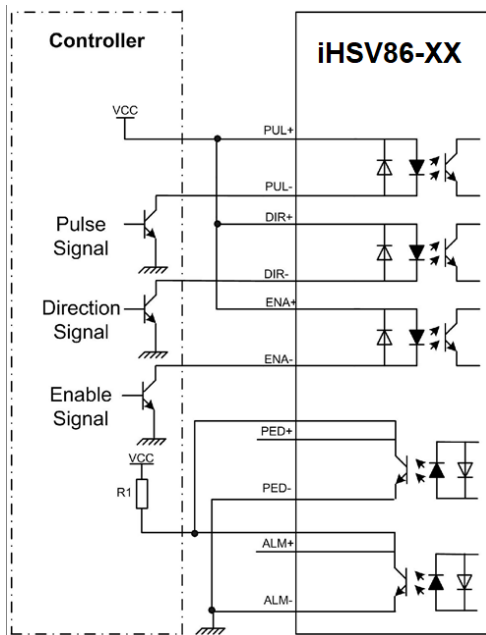

Connection to Common Cathode:

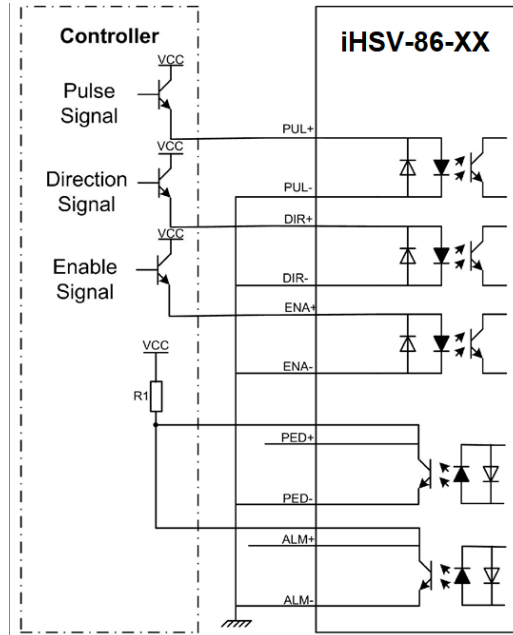

Connection to Differential Signal:

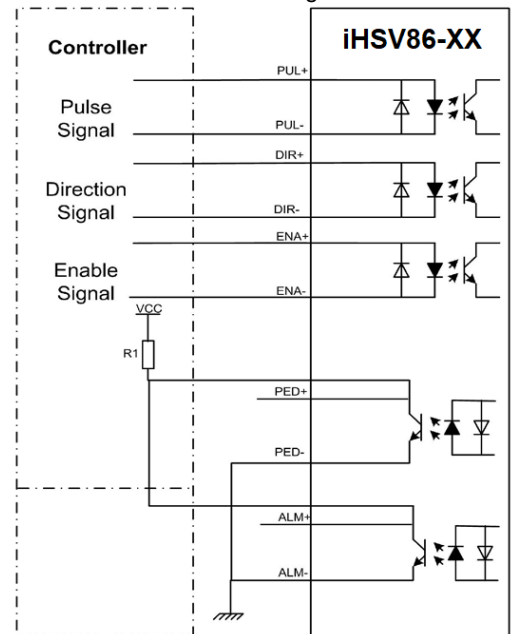

## 14. RS232 Communication Cable Connections:

**Note 1:** The RS232 communication port is not isolated. Please use a galvanic isolated power supply for the iHSS86-XX when the PC's serial port is not isolated.

**Note 2:** Do not plug or unplug the connector when power is on.

Definition		Remark
RX		Receive Data
GND		Power Ground
TX		Transmit Data
OR		
NC		Reserved
RX		Receive Data
GND		Power Ground
TX		Transmit Data
VCC		Power Supply to HISU