

# GM12-15BY

12mm gearbox plus 15mm stepper motor

Module	0.15		
Rated torque (kg.cm)	0.5 kg.cm max		
Max momentary tolerance torque (kg.cm)	1.0 kg.cm max		
Reduction ratio	1/10	1/20、1/30 1/50、1/63 1/100	1/110、1/150 1/210、1/250 1/298、1/380
Number of gear stages	2	4	5
Gearbox length L (mm)	11.5		

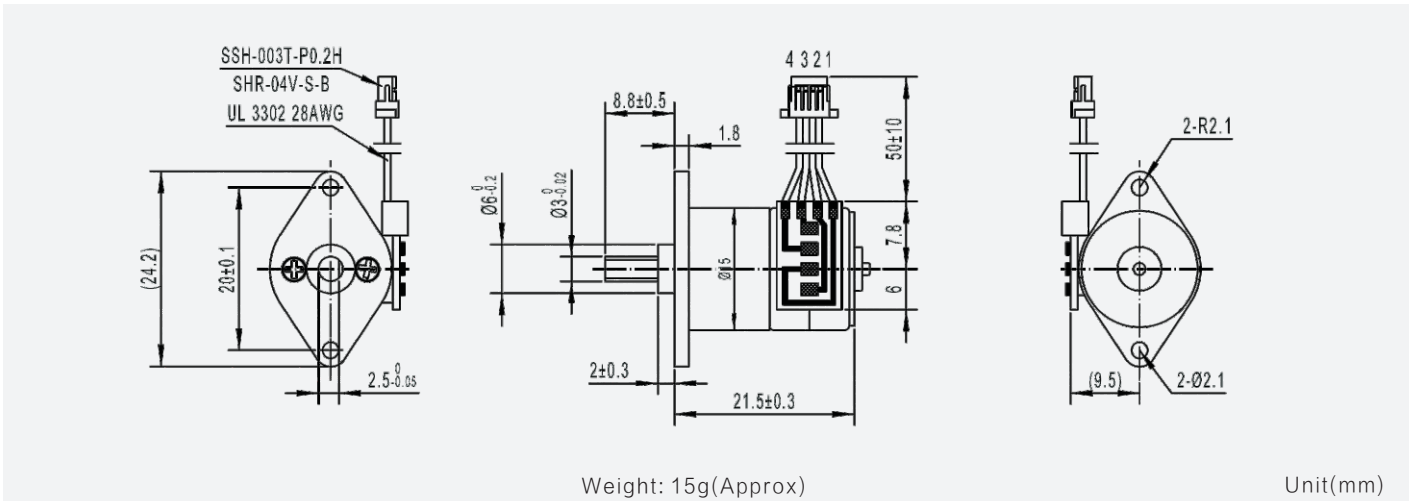

## Motor Technical Data

Motor model	Rated voltage	No. of phase	Step angle	Resistance	Current	Inductance	Detent torque	Holding torque	Pull in rate
	VDC			Ω	mA	mH	g.cm	g.cm	pps
TS-15BY45-001	5.0	2	18°	10	500	3	7.0	36	800

