

GM12-N30VA

12mm gearbox plus N30 permanent magnet DC motor

Module	0.15			
Rated torque (kg.cm)	0.5 kg.cm max			
Max momentary tolerance torque (kg.cm)	1.0 kg.cm max			
Reduction ratio	1/10	1/20、1/30 1/50、1/63 1/100	1/110、1/150 1/210、1/250 1/298、1/380	1/1000
Number of gear stages	2	4	5	7
Gearbox length L (mm)	9.0		12.0	

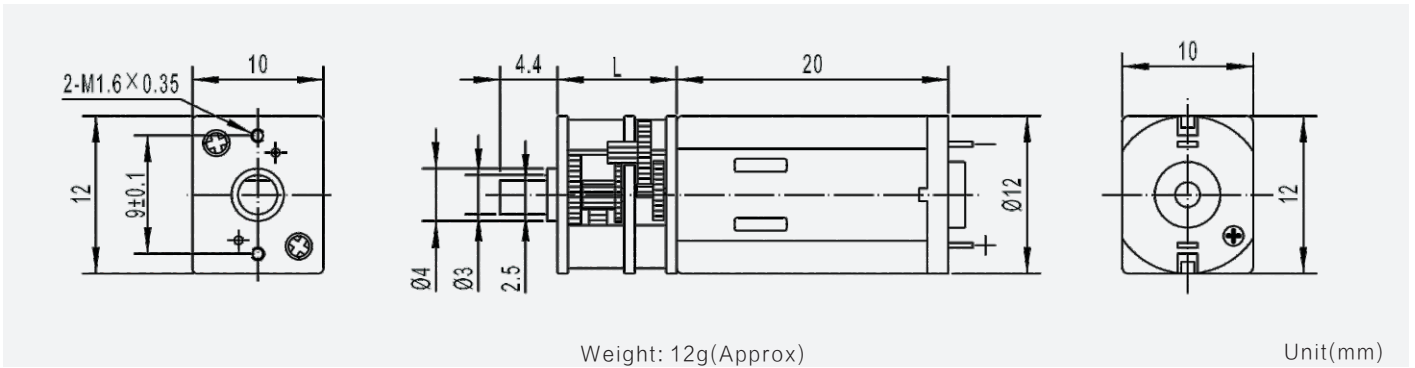
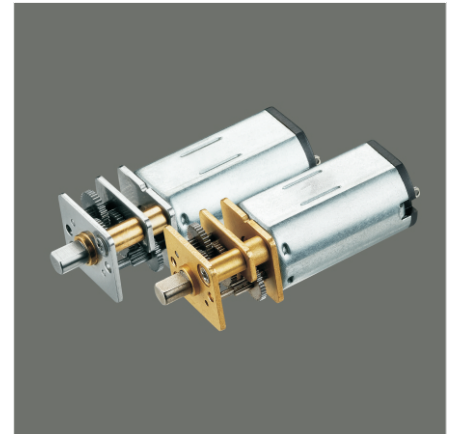

Gear Motor Technical Data

Reduction ratio		10	30	50	100	150	210	250	298	380	1000
6.0V	No-load speed(rpm)	1200	410	245	120	82	60	50	42	33	12
	Rated speed(rpm)	1070	355	210	105	70	50	42	36	28	10
	Rated torque(kg.cm)	0.024	0.06	0.09	0.18	0.25	0.35	0.38	0.45	0.5	0.5
12.0V	No-load speed(rpm)	1200	410	245	120	82	60	50	42	33	12
	Rated speed(rpm)	1040	345	205	102	68	49	41	35	27	10
	Rated torque(kg.cm)	0.024	0.06	0.09	0.18	0.25	0.35	0.38	0.45	0.5	0.5

Motor Technical Data

Motor model	Rated voltage	No-load		Rated			Stall		
		Speed	Current	Speed	Torque	Current	Power	Torque	Current
	VDC	r/min	mA	r/min	g.cm	mA	W	g.cm	A
TFF-N30VA-09190	6.0	12500	25	10600	3.0	98	0.33	20	0.50
TFF-N30VA-06350	12.0	12500	12	10400	3.0	50	0.32	18	0.25

