

# GM13-030PA

13mm gearbox plus 030 permanent magnet DC motor

Module	0.15		
Rated torque (kg.cm)	0.5 kg.cm max		
Max momentary tolerance torque (kg.cm)	1.0 kg.cm max		
Reduction ratio	1/10	1/20、1/35 1/63、1/86	1/115、1/150 1/250、1/360
Number of gear stages	2	4	5
Gearbox length L (mm)	11.0		

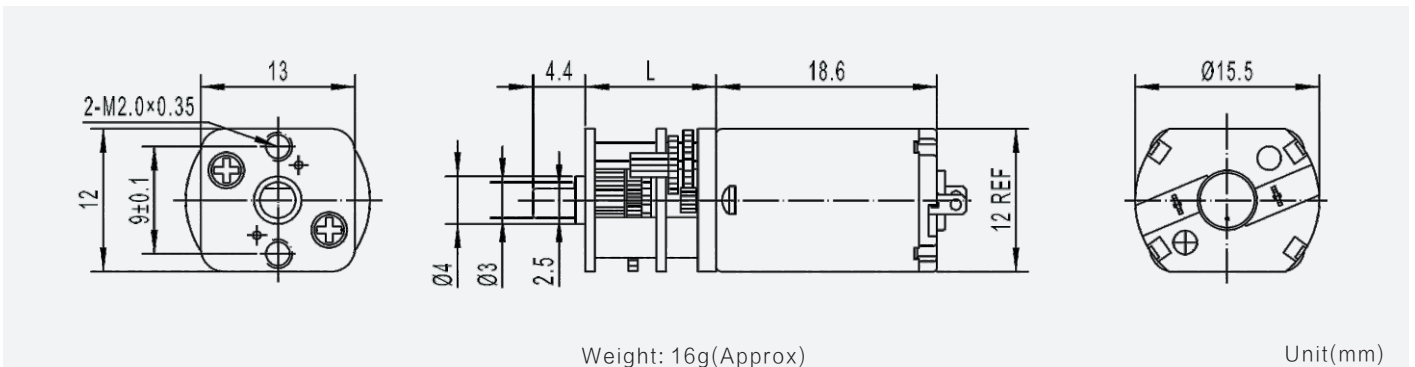
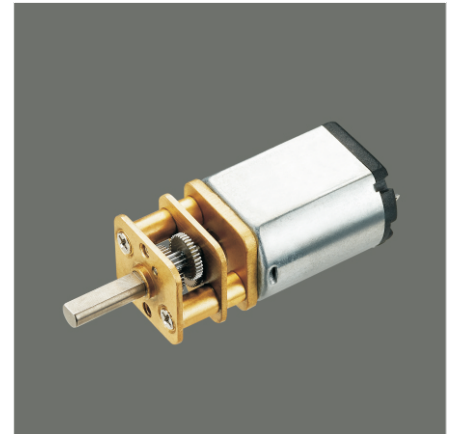

## Gear Motor Technical Data

Reduction ratio		3	10	20	35	63	86	115	150	250	360
<b>6.0V</b>	No-load speed(rpm)	3600	1100	550	310	175	130	96	73	44	30
	Rated speed(rpm)	3000	900	450	260	140	105	78	60	38	28
	Rated torque(kg.cm)	0.01	0.03	0.06	0.1	0.19	0.26	0.35	0.45	0.5	0.5
<b>12.0V</b>	No-load speed(rpm)	4000	1200	610	350	195	140	105	83	50	35
	Rated speed(rpm)	3250	975	485	280	155	110	85	65	41	30
	Rated torque(kg.cm)	0.01	0.03	0.06	0.48	0.19	0.26	1.6	0.45	0.5	0.5

## Motor Technical Data

Motor model	Rated voltage	No-load		Rated			Stall		
		Speed	Current	Speed	Torque	Current	Power	Torque	Current
	VDC	r/min	mA	r/min	g.cm	mA	W	g.cm	A
<b>TFF-030PA-09220</b>	6.0	11500	35	9000	5.0	140	0.45	23	0.60
<b>TFF-030PA-06400</b>	12.0	12500	20	9750	5.0	75	0.50	23	0.27

