

GM16-050SH

16mm gearbox plus 050 permanent magnet DC motor

Module	0.15		
Rated torque (kg.cm)	0.5 kg.cm max		
Max momentary tolerance torque (kg.cm)	1.0 kg.cm max		
Reduction ratio	1/10	1/17, 1/20, 1/35 1/63, 1/86	1/115, 1/150 1/250, 1/360
Number of gear stages	2	4	5
Gearbox length L (mm)	11.0		

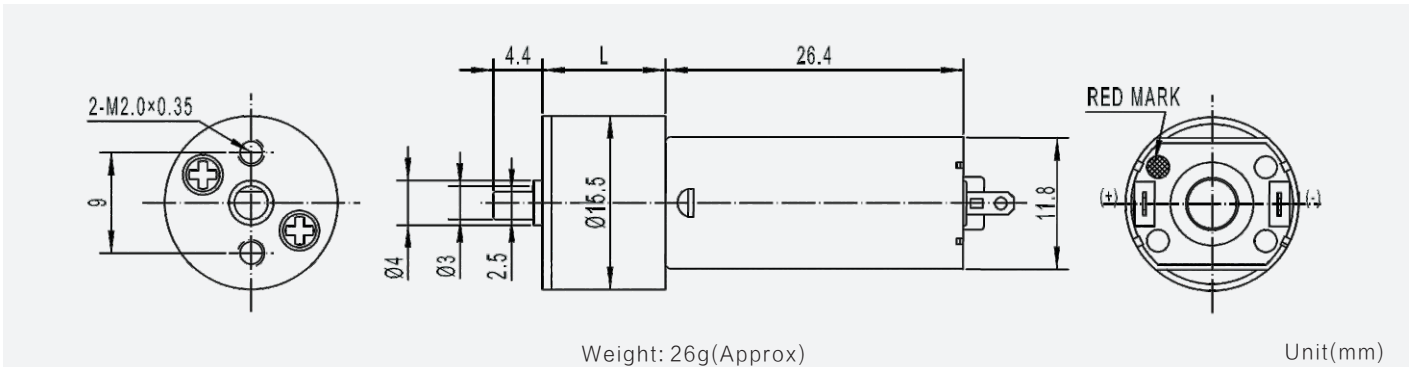

Gear Motor Technical Data

Reduction ratio		10	20	35	63	86	115	150	250	360
6.0V	No-load speed(rpm)	1200	600	340	190	140	105	80	50	35
	Rated speed(rpm)	1000	500	285	158	116	92	73	46	33
	Rated torque(kg.cm)	0.08	0.14	0.25	0.44	0.5	0.5	0.5	0.5	0.5
12.0V	No-load speed(rpm)	1230	620	350	200	145	110	85	50	36
	Rated speed(rpm)	950	475	270	150	110	82	73	46	33
	Rated torque(kg.cm)	0.08	0.14	0.25	0.44	0.5	0.5	0.5	0.5	0.5

Motor Technical Data

Motor model	Rated voltage	No-load		Rated			Stall		
		Speed	Current	Speed	Torque	Current	Power	Torque	Current
	VDC	r/min	mA	r/min	g.cm	mA	W	g.cm	A
TFF-050SH-13120	6.0	12500	45	10000	10	255	1.03	50	1.30
TFF-050SH-08240	12.0	12800	35	9700	10	150	0.99	41	0.55

