

GM20-130SH

20mm gearbox plus 130 permanent magnet DC motor

Module	0.25/0.3/0.35			
Rated torque (kg.cm)	2.5 kg.cm max			
Max momentary tolerance torque (kg.cm)	5.0 kg.cm max			
Reduction ratio	1/29、1/31	1/56、1/60 1/73、1/78	1/107、1/115 1/140、1/150 1/182、1/195	1/268、1/287 1/349、1/374 1/456、1/488
Number of gear stages	4	5	6	7
Gearbox length L (mm)	15.9	17.4	18.9	20.4

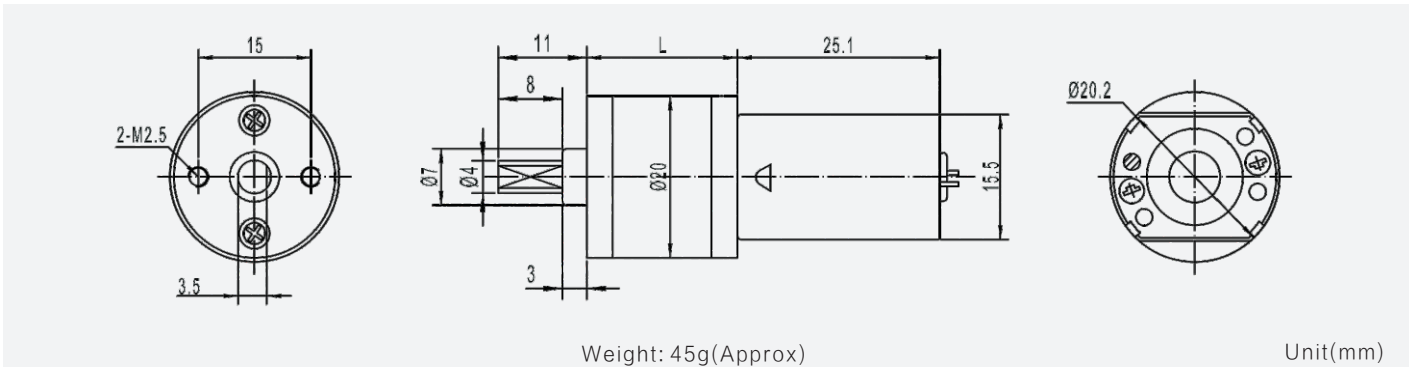

Gear Motor Technical Data

Reduction ratio		29	31	56	73	107	182	268	349	456	488
6.0V	No-load speed(rpm)	240	220	120	95	65	40	27	21	16	15
	Rated speed(rpm)	190	180	100	76	52	31	21	16	13	12
	Rated torque(kg.cm)	0.3	0.3	0.5	0.7	0.9	1.5	2.0	2.5	2.5	2.5
12.0V	No-load speed(rpm)	290	270	150	115	80	48	33	25	19	18
	Rated speed(rpm)	235	220	120	95	65	38	26	20	16	15
	Rated torque(kg.cm)	0.3	0.3	0.5	0.7	0.9	1.5	2.0	2.5	2.5	2.5

Motor Technical Data

Motor model	Rated voltage	No-load		Rated			Stall		
		Speed	Current	Speed	Torque	Current	Power	Torque	Current
	VDC	r/min	mA	r/min	g.cm	mA	W	g.cm	A
TFF-130SH-14230	6.0	7200	50	5600	15	255	0.87	65	1.10
TFF-130SH-11370	12.0	8800	40	6900	15	170	1.10	70	0.70

