

# GM24-N20VA 24 × 12mm gearbox plus N20 permanent magnet DC motor

Module	0.15	0.25
Rated torque (kg.cm)	0.5 kg.cm max	1.0 kg.cm max
Max momentary tolerance torque (kg.cm)	1.0 kg.cm max	2.0 kg.cm max
Reduction ratio	1/150, 1/350, 1/500	1/47, 1/120 1/165, 1/250
Number of gear stages	6	
Gearbox length L (mm)	9.0	

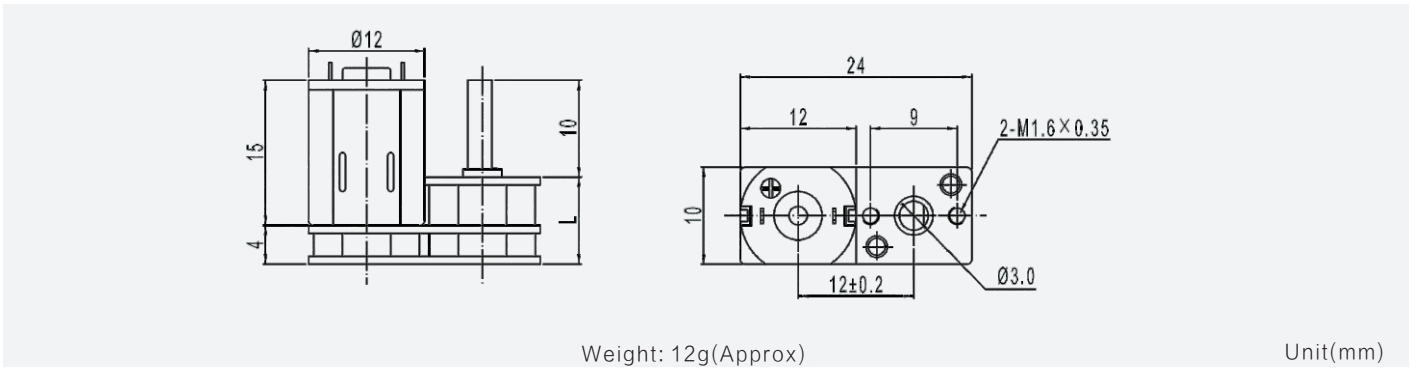

Reduction ratio		47	120	150	165	250	350	500		
2.4V	No-load speed(rpm)	300	120	96	88	58	42	30		
	Rated speed(rpm)	255	100	80	73	48	34	25		
	Rated torque(kg.cm)	0.06	0.16	0.2	0.22	0.34	0.4	0.5		
5.0V	No-load speed(rpm)	300	120	96	88	58	42	30		
	Rated speed(rpm)	255	100	80	73	48	34	25		
	Rated torque(kg.cm)	0.06	0.16	0.2	0.22	0.34	0.4	0.5		

Motor model	Rated voltage	No-load		Rated			Stall		
		Speed	Current	Speed	Torque	Current	Power	Torque	Current
	VDC	r/min	mA	r/min	g.cm	mA	W	g.cm	A
TFF-N20VA-13110	2.4	14800	60	12100	2.5	260	0.31	14	1.20
TFF-N20VA-09220	5.0	14800	30	12000	2.5	120	0.31	13	0.52

