

GM25-320SH

25mm gearbox plus 320 permanent magnet DC motor

Module	0.4						
Rated torque (kg.cm)	3.0 kg.cm max						
Max momentary tolerance torque (kg.cm)	6.0 kg.cm max						
Reduction ratio	1/4.2 1/4.4	1/9.3 1/10	1/20 1/21	1/34 1/45 1/47	1/75 1/78 1/99 1/103	1/130 1/165 1/172 1/217 1/227	1/362 1/378 1/478 1/499
Number of gear stages	2	3	4	5	6	7	8
Gearbox length L (mm)	17	19	21	23	25	27	

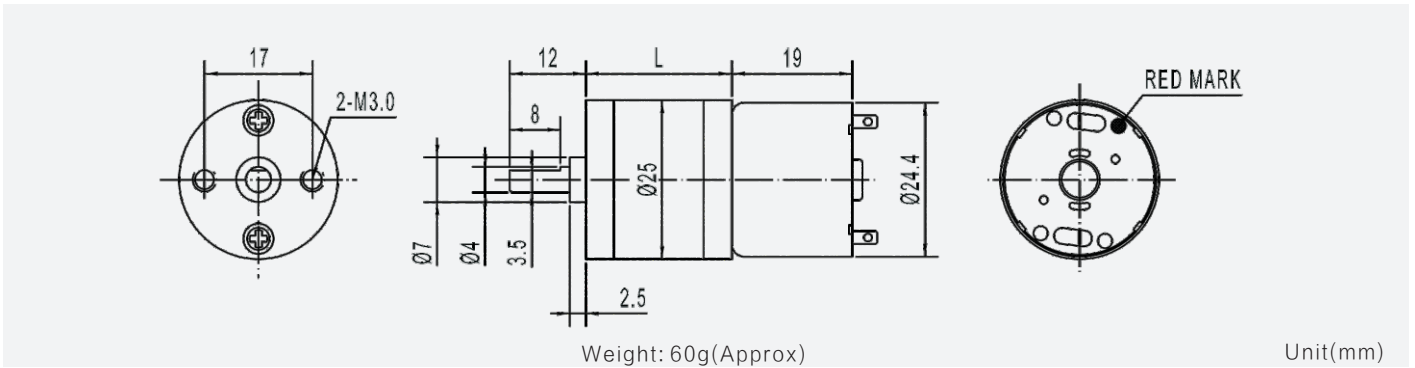

Gear Motor Technical Data

Reduction ratio		4	10	21	34	47	78	103	130	227	499
6.0V	No-load speed(rpm)	1200	480	240	145	105	60	48	37	21	10
	Rated speed(rpm)	1050	420	210	120	90	55	40	32	19	8
	Rated torque(kg.cm)	0.04	0.08	0.15	0.24	0.3	0.5	0.6	0.8	1.1	2.5
12.0V	No-load speed(rpm)	1600	650	320	190	140	85	65	50	30	13
	Rated speed(rpm)	1450	580	270	170	120	75	55	45	25	12
	Rated torque(kg.cm)	0.08	0.16	0.3	0.5	0.6	0.9	1.2	1.5	2.2	3.0

Motor Technical Data

Motor model	Rated voltage	No-load		Rated			Stall		
		Speed	Current	Speed	Torque	Current	Power	Torque	Current
	VDC	r/min	mA	r/min	g.cm	mA	W	g.cm	A
TRK-320SH-13330	6.0	5000	50	4200	10	150	0.43	63	0.7
TRK-320SD-11425	12.0	6800	50	5800	20	180	1.19	136	0.8

